



Division of Finance and Business Operations

**Request for Proposal
and Specifications for
Cohn Nursing Building Classroom Renovation**

No part of this publication may be reproduced, transmitted, transcribed, stored in a retrieval system, or translated into any language in any form by any means without the written permission of Wayne State University

**Wayne State University
Procurement & Strategic Sourcing**

July 24, 2024



Procurement & Strategic Sourcing
5700 Cass Avenue, suite 4200
Detroit, Michigan 48202
(313) 577-3734
FAX (313) 577-3747

Division of Finance and Business Operations

July 24, 2024

Dear Vendors:

IMPORTANT – PLEASE NOTE: Bid notices will be sent only to those Vendors registered to receive them via our Bid Opportunities Listserve service. To register, visit <http://go.wayne.edu/bids>, and click on the “Join our Listserve” link at the top of the page. Instructions are at the top of the page, and the **BIDS-FURNITURE@LISTS.WAYNE.EDU** Listserv service is under “**Furniture** Bid Opportunities”.

Wayne State University invites you to participate in its Request for Proposal process to provide **Cohn Nursing Building Classroom Renovation**, for the **Nursing School**, per the specifications contained herein the Request for Proposal. This service is expected to commence on **November 2024**.

We have a bid information package complete with the Request for Proposal and complete specifications available for downloading from the University Purchasing Web Site at <http://go.wayne.edu/bids> (include capitalization and underscores) as of **July 24, 2024**. When visiting the Web Site, click on the “**Furniture**” link in green. Copies of the RFP will not be available at the pre-proposal meeting.

To participate, it is **Optional** that you and/or responsible representatives of your organization attend our pre-proposal conference. For this RFP, the University offers the following Pre-Proposal Options: **Virtual**. The meeting will be held on **July 31, 2024, 10:00 am (Eastern - Detroit Time)**.

Vendors who would like to participate in the pre-proposal meeting via a TEAMS Video Conference or Conference Call, may do so via the information below:

**Microsoft Teams Meeting
On-line or via Conference Call**

[Join the meeting now](#)

**Need to join from a mobile device but don't have TEAMS on it?
[Visit our website](#) for instruction on adding TEAMS to your device.**

Attendance will be taken during the Prebid Meeting. When Pre-proposal Meetings are **Optional**, nominal scorecard points will be awarded for attendance.

We **hope you can join us** at the **Optional** pre-proposal meeting. Please **have a copy** of this Request for Proposal for your reference during the meeting. Should you have any questions or concerns about this invitation, please contact me at **(313) 577-3720**, or email: **rfpteam2@wayne.edu**. Thank you for your interest in doing business with Wayne State University.

Sincerely,

**Valerie Kreher
Senior Buyer**

Enclosure

**RFP: Cohn Nursing Building Classroom Renovation
for the Nursing School**

	<u>Page No.(s)</u>
I. <u>Introduction</u>	1
II. <u>Information for VENDOR</u>	1
A. General	2
B. Calendar of Events	2
C. Optional Pre-Proposal Meeting	2
D. Examination of the Request for Proposal	2
E. Delivery of Proposals	3
F. Proposal Format	3
G. Proposal Evaluation	4
H. VENDOR Profile, Experience, References and Lost Accounts	4
I. VENDOR Service Plan	5
III. <u>Scope of Work and Project Requirements</u>	6
IV. <u>General Requirements and Guidelines</u>	7

UNIVERSITY PROVIDED SCHEDULES

Schedule A	Proposal Certification, Non-Collusion Affidavit, VENDOR Acknowledgements
Schedule B	Insurance Requirements
Schedule C	Cost Schedule
Schedule D	Summary Questionnaire

VENDOR CREATED EXHIBITS - TO BE SUBMITTED WITH VENDOR PROPOSAL

VENDOR Exhibit 1	Exceptions / Restricted Services
VENDOR Exhibit 2	Profile/Experience/References
VENDOR Exhibit 3	Service Plan
VENDOR Exhibit 4	Sample Management Reports

APPENDICES

Appendix 1	Wayne State University Map – (see website: http://campusmap.wayne.edu)
Appendix 2	New Vendor Set-Up Requirements
Appendix 3	WSU Wage Rate Schedules
Appendix 4	Drawings
Appendix 5	Sample Strategic Source Agreement



I. **INTRODUCTION**

- A. **Wayne State University**, founded in 1868, is committed to preparing its students to excel in a fast-paced and interconnected global society. It combines the academic excellence of a major research university with the practical experiences of an institution whose history, location and diversity make it a microcosm of the world students will enter when they graduate. The University holds the Highest Carnegie Foundation classification for research activity. It has 13 colleges and schools and offers more than 350 academic programs including bachelor’s, master’s and doctoral degrees; post-baccalaureate, graduate and specialist certificates; and three professional programs (<http://wayne.edu/about/facts/>).
- B. Procurement & Strategic Sourcing is soliciting proposals from qualified professional organizations, hereafter referred to as VENDOR(s), who specialize in providing **Cohn Nursing Building Classroom Renovation** of superior quality, at competitive pricing, as described in the Statement of Work section of the **Request for Proposal (RFP)**. **Project must commence on or before November 2024 and be completed by December 20, 2024.**

This RFP outlines basic requirements as specified in the Scope of Work section of the RFP (Section III). Proposals submitted are to be in accordance with the outline and specifications contained in and are to remain in effect a minimum of **120** days from the date of submission and may be subject to further extensions as negotiated.

- C. **The UNIVERSITY reserves the right to accept, reject, modify, and/or negotiate any and all proposals received in conjunction with the RFP.** It reserves the right to waive any defect or informality in the Proposals on the basis of what it considers to be in its best interests. Any proposal may be rejected which the UNIVERSITY determines to be incomplete, conditional, obscure, or has irregularities of any kind. The UNIVERSITY reserves the right to award to the firm, or firms, which in its sole judgment, will best serve its long-term interest.

This RFP in no manner obligates the UNIVERSITY to the eventual purchase of any products or services described, implied, or which may be proposed, until confirmed by written agreement, and may be terminated by the UNIVERSITY without penalty or obligation at any time prior to the signing of an Agreement or Purchase Order.

- D. Expenses for developing and presenting proposals shall be the entire responsibility of the VENDOR and shall not be chargeable to the UNIVERSITY. All supporting documentation and manuals submitted with this proposal will become the property of the UNIVERSITY.
- E. All questions concerning this Request for Proposal are to be directed to **Valerie Kreher, Senior Buyer**, Email; rfpteam2@wayne.edu. The deadline for questions is **August 5, 2024, 12:00 noon**. Under no circumstances may a VENDOR contact other individuals at the UNIVERSITY, or its consultants to discuss any aspect of this RFP, unless expressly authorized by Procurement & Strategic Sourcing to do so.

II. **INFORMATION FOR VENDOR**

A. **General**

This RFP contains requests for information. VENDORS, however, in responding to this RFP, are encouraged to provide any additional information they believe relevant. VENDORS are encouraged to examine all sections of this RFP carefully, in that the degree of interrelationship between sections is high.

B. **Calendar of Events**

<u>Activity</u>	<u>Responsibility</u>	<u>Date</u>
Formal Release of RFP	Procurement	July 24, 2024
Optional Pre-Proposal meeting	Procurement /Evaluation Team (ET)/VENDORS	July 31, 2024 10:00 am

Questions due to Procurement & Strategic Sourcing	VENDORS	August 5, 2024 - 12 Noon
Delivery of Proposals are by electronic submission on August 8, 2024. The link for bid submission will be posted with the bid details at http://go.wayne.edu/bids .	VENDORS	August 8, 2024 by 2:00 p.m.
Evaluation of Proposals (clarifications & negotiations)	Procurement / E	Week of Mid-August 2024
Announcement of Selected VENDOR	Procurement	Week of September 2024
Readiness for Service/Contract Commencement	VENDORS	Week of November 2024
Project Completion	VENDORS/ET	December 20, 2024

The UNIVERSITY will make every effort to adhere to the above schedule. It is subject however, to time extensions at the University's discretion.

C. Optional Pre-Proposal Meeting

You may attend a **Optional Pre-Proposal Meeting** on as a condition for submitting a proposal. For this RFP, the University offers the following Pre-Proposal Options: **Virtual**

The meeting will be held on **July 31, 2024, 10:00 am (Eastern - Detroit Time)**.

Vendors who would like to participate in the pre-proposal meeting via a TEAMS Video Conference or Conference Call, may do so via the information below:

**Microsoft Teams Meeting
On-line or via Conference Call**

[Join the meeting now](#)

Need to join from a mobile device but don't have TEAMS on it?

[Visit our website](#) for instruction on adding TEAMS to your device.

During this meeting, we will answer any questions you may have to clarify any ambiguities in this Request for Proposal. Answers to questions that cannot be answered during this meeting will be put into an Addendum and emailed to all VENDORS and posted to the University website as soon as they are obtained. Each proposal submitted shall list all addenda, by numbers, which have been received prior to the time scheduled for receipt of proposal.

Attendance will be taken during the Prebid Meeting. When Pre-proposal Meetings are Optional, nominal scorecard points will be awarded for attendance.

Minutes for the Pre-proposal Meeting will be distributed and published on the website as an Addendum. Vendors are responsible for the information in this and all other Addenda, and must acknowledge each addendum in Schedule D on the second page of the Schedule.

D. Examination of the Request for Proposal

Before submitting proposals, each VENDOR will be held to have examined the UNIVERSITY requirements outlined in the Scope of Work and Technical Information sections and satisfied itself as to the existing conditions under which it will be obligated to perform in accordance with specifications of this RFP.

No claim for additional compensation will be allowed due to unfamiliarity with the specifications and/or existing conditions. It shall be understood that the VENDOR has full knowledge of all of the existing conditions and accepts them "as is."

E. Delivery of Proposals

Proposals with supporting documentation shall be submitted **by electronic submission**. The link for bid submission will be posted with the bid details at <http://go.wayne.edu/bids> beginning **July 24, 2024**.

The electronic submission should be limited to no more than one of each of the following file types: 1 Word Document and/or 1 Excel Workbook and/or 1 PDF document, with a total file size less than **20 megabytes**. **ZIP Files containing separate sections of a proposal are not acceptable, drop box submissions are not accepted either**. If your submission was sent correctly, you will receive an auto-reply message acknowledging receipt of your Proposal.

The specific format for responses is detailed in **Section II F** (below). Proposals and **Schedule C, Cost Schedule** must be signed, and the authority of the individual signing must be stated thereon. All responses are to be submitted **by electronic submission** on forms furnished with the Bidding documents:

ATTN.: **Valerie Kreher, Senior Buyer**
Wayne State University
RFP: Cohn Nursing Building Classroom Renovation

The link for bid submission will be posted with the bid details at <http://go.wayne.edu/bids> beginning **July 24, 2024**.

Deadline for receipt of proposals by Procurement & Strategic Sourcing is, **August 8, 2024 by 2:00 p.m. (local time)**. **Proposals received after that time will not be accepted**. No details of the proposal will be divulged at the time of opening.

F. Proposal Format

Proposals are limited to **25 pages total**, one sided, and eleven (11) point font. (This is inclusive of all required documents and schedules and any optional material included at the discretion of the respondent, but tab sheets and the cover pages do not count in the overall document count.)

Proposals are to be submitted with appropriate indices. Each proposal should provide a straightforward concise description of the VENDOR'S service, approach and ability to meet the UNIVERSITY'S needs as stated in this RFP. Schedules and Exhibits listed below must be included in your proposal:

University Provided Schedules (provided in this package)

- Schedule A - Proposal Certification, Non-Collusion Affidavit, VENDOR Acknowledgements
- Schedule B - Insurance Requirements
- Schedule C - Cost Schedule, Summary of Quoted Rates
- Schedule D - Summary Questionnaire

Vendor Created Exhibits (to be Submitted with Vendor Proposal)

- Exhibit 1 - Exceptions/Restrictions, if any exist (**Section II G**)
- Exhibit 2 - Profile / Experience / References (**Section II H**)
- Exhibit 3 - VENDOR Service Plan (**Section III**)

Care should be exercised in preparation of the proposals since it is the UNIVERSITY'S intent to have the final contract documentation to consist of a University Strategic Source Agreement (Appendix 5) that incorporates the RFP, VENDOR Proposal, any letters of clarification, and will require the issuance of a Purchase Order for invoicing purposes.

Unnecessarily elaborate brochures or other presentations beyond those sufficient to present a complete and effective quotation are not desired.

G. Proposal Evaluation



1. Proposals will be evaluated, and award will be based on the VENDOR'S ability to offer the best value (quality, past performance and price), and on anticipated quality of service. Items considered include but are not limited to:
 - Ability to meet all mandatory requirements and specifications of this RFP.
 - Cost of Services; Compensation and Fees; (Schedule C).
 - Financial Strength of the VENDOR.
 - Proposal Documentation / Presentation.
 - VENDOR'S Experience (Exhibit 2).
 - VENDOR Profiles/References; (Exhibit 2).
 - VENDOR Service Plan; (Exhibit 3).

NOTE: Evaluation Criteria are in alphabetical order and are not stated in order of preference.

VENDOR proposals will be evaluated by a team consisting of members of the UNIVERSITY'S Purchasing and **Nursing School**. A preliminary screening will be used to identify competitive VENDORS who have met the mandatory requirements. Procurement & Strategic Sourcing may subsequently request selected VENDORS to attend an interview or make a presentation at a set time and date, to clarify information provided in the proposals. Final consideration, evaluation, and recommendation may be made at this point. However, the UNIVERSITY reserves the right to take additional time for reference review, site visits and/or proposal negotiations.

2. To qualify for evaluation, a VENDOR'S proposal must be responsive, must have been submitted on time and must materially satisfy all **mandatory requirements** identified throughout the RFP, in the judgment of the UNIVERSITY. **Any deviation from requirements indicated herein must be stated in the proposal specifically under the category "Restricted Services", and clearly identified as Exhibit 1.** Otherwise, it will be considered that proposals are in strict compliance with all requirements. Check the box indicating "None" for Restricted Services on the Proposal Certification Schedule A. In those cases where mandatory requirements are stated, material failure to meet those requirements may result in disqualification of the VENDOR'S response
3. If there are portions of any proposal the UNIVERSITY finds unacceptable or otherwise in need of clarification or revision, the UNIVERSITY reserves the right to clarify or negotiate with any or all VENDORS. Should the outcome of evaluations result in a recommendation, any resulting contract will be subject to the approval of the UNIVERSITY'S General Counsel and must be approved and signed by the appropriate UNIVERSITY representative.
4. After notification of acceptance of proposal and the signing of a resulting agreement and/or Purchase Order, the successful VENDOR will be expected to establish and be in a position to **commence work or services on or before November 2024.**

H. VENDOR Profile, Experience, References, and Lost Accounts

1. VENDOR Profile should include:

VENDOR is required to provide organizational data that demonstrates the size, scope and capability of the Company to handle the UNIVERSITY'S specific requirements specified in this RFP. Explain any company relationships that could be construed to be a conflict of interest in doing business with the UNIVERSITY now or in the future.

Upon University request, **VENDOR must agree to provide publicly distributed annual reports and/or independently audited financial statements** including its statement of financial position, statement of operations, and statement of cash flows for at least the past three years. Vendor must further agree to permit the UNIVERSITY, upon request, to audit VENDOR's books, but only as it relates to the Wayne State University account, including invoicing, operational, and technology controls (when applicable). The University is limited to 1 request per calendar year of this agreement.

If / when requested, failure to agree to this will result in disqualification of your bid (see Schedule D).

Financial Information will be treated as confidential and not added to the publicly permanent RFP file. Requested Financials must be sent to:



ATTN.: Kenneth Doherty, Associate Vice President
Procurement & Strategic Sourcing
Wayne State University
RFP: Cohn Nursing Building Classroom Renovation
Procurement & Strategic Sourcing
5700 Cass Avenue, 4th Floor - Suite 4200 AAB
Detroit, MI 48202

VENDORS must include a self-addressed envelope marked "Confidential" with their financial statement. Statements will be returned upon completion of any University review.

2. Experience

VENDORS are to state in their proposals their qualifications to meet the RFP specifications in terms of past and current consulting experience with the same or similar requirements. This information should be provided in the VENDOR'S **Exhibit 2** of their proposal. VENDORS are to focus on experiences with organizations having needs similar to that of the UNIVERSITY.

3. References

Upon request, **VENDOR must agree to provide a minimum of three (3) qualified references.** Requests for references will come from **Valerie Kreher, Senior Buyer**, and will be treated as confidential and not added to the publicly permanent RFP file.

References are to be from organizations that have successfully utilized the products and services. The references supplied should include the name and address of the organization, and the contact's name(s), titles, e-mail, and the telephone numbers.

Failure to provide references (if requested) will result in disqualification of your bid.

4. Lost Accounts and Legal Actions

Upon request, **VENDOR must agree to provide a list of significant accounts that the VENDOR has lost during the past three (3) years. "Significant" for this purpose shall be construed to mean accounts representing billings by the VENDOR in the range of \$25,000.00 or more each year. A lost account can be defined when the vendor has been terminated on a job because of performance or default. Contact names and telephone numbers of affected Companies must be provided.**

Indicate any significant past or pending lawsuits or malpractice claims against the VENDOR.

I. **VENDOR Service Plan**

Vendors should include a complete description of the products and services offered in their Proposal. The Service Plan should include, but not be limit to:

1. A summary of the products or services to be provided.
2. When applicable, a timeline showing how the Vendor plans to deliver products and/or services to fulfill any contract issued as a result of this RFP.
3. Key staff members at the Vendors organization that will be assigned to the University account or will otherwise be part of an implementation team.
4. Any resource requirements on the part of the University necessary in order for the Vendor to meet its obligations under an agreement resulting from this RFP.
5. Any hardware, software, or other technology the University must have in order to use the Vendors products or services.
6. Any alternative ideas or proposals that should be considered by the University in addition to the base proposal.

III. **SCOPE OF WORK AND PROJECT REQUIREMENTS**

The UNIVERSITY is seeking proposals for furniture for the Cohn Building at 5557 Cass Ave, Detroit, MI 48202.

The detailed specifications for the furniture are included in this Request for Proposal package (on the website).

Alternate product will be accepted.

Drawings and specifications are available on the web site. VENDORS are encouraged to carefully review the specifications and must provide pricing on paper and electronically using Microsoft's Excel or Lotus 1-2-3. If VENDORS products exceed the number of components indicated by the item or line number, VENDOR must list components with decimal subscript of that base item number. For example if line item A1 calls for a product that VENDOR can provide via multiple components, VENDOR must provide each component as A1.1, A1.2, A1.3 etc.

The UNIVERSITY reserves the right to adjust the quantities required for this project as best meets its needs. If awarded this project, the VENDOR will work with the Design Consultant on any required changes to the colors and finishes if an "equal to" substitution is approved and awarded. The furniture as specified indicates the final selection of colors and finishes as approved by FP&M.

If a quick ship program is available for the type of furniture that is specified in Appendix 3, VENDORS are encouraged to provide a second Price Summary, Cost Schedule C., referred to as "Quick Ship Alternative Proposal".

General Notes:

- i. Vendor responsible for all delivery, uncrating, assembly, installation and removal of all packaging material.
- ii. Delivery to be scheduled with WSU Project Manager between 7:30am and 4:00pm.
- iii. State of Michigan tax is not required.
- iv. WSU may award contract to one vendor for all items.

B. Instructions to VENDORS

1. Should a VENDOR find discrepancies in, or omissions from the specifications, plans, drawings, details, instructions and bid proposal form, or should he/she be in doubt as to the meaning, he/she should notify, at once, the University Purchasing Department.

Valerie Kreher,
E-Mail address: ab4889@wayne.edu

Written responses will be sent to all appropriate VENDORS.

2. All information issued prior to the close of the bidding period shall be included in returned bid proposals and acknowledged on the Bid Proposal form.
2. It is the VENDOR'S responsibility to note any detail or specification that, in his/her opinion, is not practical or functional.
3. VENDOR shall install all furniture using their own installation crew or note name of installation company, and include appropriate experience and reference information for same.

C. Pricing



1. The VENDOR selected to provide and/or install the furniture specified in this document shall guarantee all unit prices for twelve (12) months from date of the vendor's proposal.
2. Prices are to be entered on Schedule C, listing separately the estimated freight charges and installation costs by groupings as indicated. In all cases VENDOR must observe the established Schedule C.

D. Production Schedule

1. Each VENDOR shall provide with its proposal a schedule showing time required to (a) produce shop drawings, if applicable, (b) complete production runs, (c) complete delivery and installation, if applicable.
2. The VENDOR shall work with the Manufacturer and its representative to establish delivery schedules.
3. The VENDOR shall monitor and expedite fabrication of all furniture items. Every effort shall be made to assure that schedules will be met and that specifications are being followed accurately.
4. The UNIVERSITY shall require periodic reports from the VENDOR on the status of all orders.

E. Delivery

1. VENDOR shall guarantee delivery between 7:30 A.M. and 4:00 P.M. Delivery will be at the following location:

**Wayne State University
Richard Cohn Memorial Building,
5557 Cass Ave, Detroit, MI 48202**

2. The VENDOR shall check to ensure that all items delivered are in accordance with the specifications and shall be responsible for notifying the Manufacturer in the event of any discrepancies.
3. **DAMAGED OR DEFECTIVE FURNITURE SHALL BE REPLACED AND/OR REPAIRED AT NO COST TO THE UNIVERSITY.**
4. Freight charges are to be estimated and included on Schedule C. This cost will be adjusted up or down according to actual submitted freight bills.

F. Installation

1. Installer must remove all packaging and waste material from the site. Installer is to provide a dumpster and/or haul waste materials from the site. No dumpster will be available on site.

G. Damage to Furniture

1. The VENDOR is responsible for all damages and losses until the installation has been completed and accepted by the Design Consultant and UNIVERSITY. Damage attributed to the installer shall be corrected by the Installer. The UNIVERSITY will judge the damage. An additional furniture Punchlist shall be submitted to the VENDOR after installation if any items need to be adjusted or replaced.

H. Future Orders



1. There shall be no minimum order requirements for any items specified in this specification for two (2) years from delivery date.
2. Each Manufacturer shall guarantee the availability of specified product for two (2) years from delivery date.
3. The UNIVERSITY requires price protection for additional furniture for this or other UNIVERSITY purchases for a 12 month period from the date of the purchase order (See Schedule C).

I. Finishes

1. The Design Consultant shall coordinate any color and finish changes if required after award of order.
2. All furniture items should be specified with finishes as indicated, unless noted otherwise in the Detailed Specifications.
3. See specification for additional information.

J. Submittals (for Successful VENDOR)

A. Maintenance

1. Printed maintenance and cleaning instructions as approved by each furniture manufacturer - four (4) copies must be issued to the UNIVERSITY.

B. Samples

1. Chair samples may be requested for the department to evaluate prior to awarding the bid.
2. Site visits may be requested of the top qualifying bidders. Site visits must be within the local/ southeast Michigan area or a mock-up can be provided as an alternative.

K. Order Deletions

1. UNIVERSITY reserves the right to deduct twenty percent (20%) from the original specification quantities without any effect on the unit prices submitted.

L. Warranties

- A. The Manufacturer shall provide the UNIVERSITY with written documentation which guarantees all items against defects in materials, manufacture and workmanship, for a period of ten (10) years from the day of final settlement with UNIVERSITY for the item. Final settlement shall not relieve the Manufacturer from liability for such defects, and upon notification from UNIVERSITY, the Manufacturer shall, by repair, replacement, or otherwise, place the item in a condition satisfactory to the UNIVERSITY in every respect. Usual wear and tear and results of accidents not chargeable to the Manufacturer are exempted from the requirements of this guarantee. Everything required to fulfill this guarantee shall be done without additional cost to the UNIVERSITY. The products or workmanship of any Subcontractor are to be covered in the primary Manufacturer's guarantee.
- B. The following shall be considered defects, without being limited thereto:
 1. Permanent etching, staining, and other deterioration of finishes.
 2. Operational failures, binding, and the like, in finish and cabinet hardware.



3. Deformation, warpage, opening up of joints, telegraphing of cores, delamination of veneers, or other finishing materials, failures in fastening and anchorage, sagging of panels.
4. Discoloration, fading and staining of finishes.

M. General Notes (Deleted)

N. Responsibility

DESIGN CONSULTANT RESPONSIBILITIES

- A. The Design Consultant and FP&M shall be the interpreter of all work covered in this bid document.
- B. The Design Consultant and FP&M shall visit the project periodically to observe the work. After installation, final review of all furniture will be made and the designer shall work with the UNIVERSITY in establishing a punch list of necessary corrections to furniture.
- C. Approval of all materials, finishes colors, and details shall be made by the Design Consultant and the UNIVERSITY.
- D. The UNIVERSITY and the Design Consultant shall reserve the authority to stop work on a given segment of work or item to ensure the proper interpretation and execution of the requirements of this specification.
- E. All questions/concerns with regard to product and installation shall be directed to the Design Consultant. (Once an award has been made.)

VENDOR RESPONSIBILITIES

- A. Delivery and installation shall be done in one phase. The VENDOR shall work with the Design Consultant, the Owners Representative and the General Contractor to set-up an acceptable delivery schedule. Vendor must notify design consultant, the Owners Representative and the General Contractor of any lead-time problems as soon as they are known.
- B. The VENDOR shall oversee and administer the receipt and storage of furniture and shall include in the bid pricing any additional charges for this service, if required, based on the schedule outline in item A, above.

C. FINISH SPECIFICATIONS

Each Manufacturer shall submit two (2) finish samples of finishes for paint, plastic laminate, metal, edge and trim samples which are representative of the production runs to be used for this project as specified and for "equal to" substitutions for review. Finish samples shall be furnished to Design Consultant and FP&M. These samples will be as specified in this specification for design, color, quality, and appearance.

- D. Schedule C is an incomplete specification. VENDOR must use the complete specification sheet in Appendix 3.
- E. The VENDOR takes full responsibility that all components (glides, brackets, trim, hardware, etc.) are included in the proposal so that at completion of installation all products will be fully functional and aesthetically complete.

INSTALLER/ VENDOR RESPONSIBILITIES



- NOTE:** It is assumed that the VENDOR possesses its' own in-house installation crew with qualified personnel to install this job. If this assumption is not true, indicate any and all sub-contractors and qualifications. Sub-contractor is bound by all conditions and requirements as would a VENDOR'S own in-house installation crew. VENDORS must provide 3 references for any subcontractors that will work on the project.
- A. Installers are required to furnish all labor, incidental materials, equipment, supplies, supervision, and all other things necessary to receive, inspect, assemble, place, level and clean shelving in specified locations in UNIVERSITY'S building, and to do all other things necessary to perform a complete installation of items under this agreement.
 - B. Installer shall identify one person, acceptable to the UNIVERSITY, who shall act as liaison with the UNIVERSITY and Design Consultant. This individual must have the authority to make decisions on behalf of the Installer.
 - C. All drawings, specifications, and other documents provided by the Design Consultant are to be carefully examined. Error is to be brought to the attention of the Design Consultant.
 - D. Installer shall meet with the General Contractor and University Representative for a Pre-installation coordination meeting at least one week before installation commences. Installer will not be allowed in the building until this meeting takes place. However, the VENDOR shall maintain responsibility for on-time installation.
 - E. Installer shall be responsible to ensure that all items are installed level, properly aligned and true, and located as shown on the furniture plans.
 - F. Installer shall provide plywood or Masonite protection to carpeting and tile when large items of furniture are moved into place. Installer shall not load the floor in excess of 100 lbs per square foot.
 - G. Installer shall be responsible for coordinating the schedule of elevator services for hoisting furniture with General Contractor (If necessary).
 - H. Installer shall remove from the project all his waste materials and rubbish resulting from his operations and shall remove all packing cartons and debris after completion of the installation of furniture. Installer to provide a dumpster at the site to contain all waste and to schedule routine removals (if necessary). Location of dumpster to be coordinated with the Facilities Planning and Management.
 - I. Installer shall take all reasonable precautions for the safety of his work, all items or materials to be installed which are in his custody, adjacent property, other workmen at the site, and the public. The Installer shall be responsible for any damage or injury due to his acts or neglect. Should the Installer fail to properly restore any damaged property, the UNIVERSITY may make all necessary repairs and deduct the cost thereof from the Installer's contract price. Installer shall comply with the General Contractor's Project Safety Program which is in accordance with MIOSHA. Hard hats and proper foot attire and clothing will be required. Installer must provide its safety policy to the General Contractor at the pre- installation meeting
 - J. Installer shall provide an adequate number of qualified, experienced personnel, in harmony with other workers at the site, capable of performing the required work within the time frames set forth in the UNIVERSITY'S schedule.
 - K. All workmen and sub-contractors performing work shall be skilled in their respective trades. Electrical work; placing, mounting, and wiring fixtures or electrical components shall be performed by union electricians, if required by local law. Electrical details and coordination of electrical installation will be with the Maintenance Trades Department of Facilities Planning and Management.



- L. Installer shall execute final cleaning just prior to acceptance of the entire work. Remove all protective materials, clean all surfaces of dirt, smears, finger marks, and all other contamination and foreign or extraneous matter.
- M. Installer shall use cleaning agents and solvents which will not damage material and finishes, as recommended for the purpose of the manufacturer of the material to be cleaned.
- N. Installer shall inspect materials and finishes for damage and faulty installation, and repair, make good or replace materials and finishes as directed, at no cost to the UNIVERSITY.
- O. Installer shall inspect, test, lubricate, and adjust all operating hardware. Installer shall also repair, make good, or replace defective or damaged parts, components, and other items at no cost to the UNIVERSITY.
- P. Installer agrees that, in the performance of its work under this contract, it shall abide by and comply with all applicable Federal, state and local laws, codes and regulations, including, but not limited to the Occupational Safety and Health Act of 1970.
- Q. Installer shall be responsible for providing padding for elevator cabs, unless padding is already installed for other purposes.
- R. No on site parking is available. Paid parking is available. Parking fees are per entrance per car and the fee is \$6.50 per access. These charges must be included in your bid. No extra charges for parking will be allowed.
- S. The location requirements and furniture code items are indicated on the enclosed furniture floor plans.
- T. The specific requirements for each type of item are indicated on the specification sheets included hereinafter.
- U. Each individual item shall have a manufacturer's tag with model numbers, design consultant's furniture code, and the room number in which the item is to be placed.
- V. It shall be the responsibility of the contractor to verify all local conditions, corridor elevators and stair, etc. and to allow installation of large furniture items. Items determined to be too large to negotiate and fit shall be manufactured in sections and assembled at the site.

UNIVERSITY RESPONSIBILITIES

- A. The UNIVERSITY and its Design Consultant shall reserve the authority to stop work on a given segment of work or item to ensure proper interpretation and execution of the requirements of this specification.
- B. UNIVERSITY shall familiarize themselves with and follow Manufacturer's recommended guidelines for maintenance and cleaning.
- C. UNIVERSITY will inspect and accept or reject items being delivered. All paperwork noting condition of furniture will be initialed by Design Consultant or FP&M. All claims and damages, minor repairs and cleaning will be under the guidance and supervision of the UNIVERSITY and VENDOR. UNIVERSITY will inform VENDOR of missing or damaged items for reorder.
- D. The UNIVERSITY and Design Consultant shall conduct a final review of all merchandise ordered to assure that all items meet specifications, are in new and undamaged condition, are assembled or installed properly and placed in their properly designated locations.
- E. The UNIVERSITY shall notify the VENDOR of areas ready to receive furniture.

IV. GENERAL REQUIREMENTS AND GUIDELINES

A. Terms and Conditions

Any contract between the UNIVERSITY and VENDOR resulting from this RFP will be made using the University's Strategic Source Agreement (Exhibit V). The Agreement will incorporate this RFP and its terms and conditions by reference. Should the Vendor have additional terms to incorporate into the Agreement, the Vendor's Proposal response must include a formal copy of any VENDOR'S terms and conditions applicable to this transaction. Evaluation and acceptance and/or modification of these terms and conditions by the University's General Counsel is essential prior to the award of the contract. If supplied, this should be included in **Exhibit 1** of the Vendor's proposal. **In the event the VENDOR does not supply terms and conditions with their proposal, the University's terms and conditions will govern this transaction.**

B. Joint or Partnering Bids/Proposals

A joint bid/proposal by two or more Vendors proposing to participate jointly in performance of proposed work may be submitted. A single Vendor must be clearly identified as the "Primary Vendor" who will assume responsibility for performance of all other Vendors and all subcontractors. The Primary Vendor must identify itself as such and submit the proposal under its company name and signature. If a contract is awarded in response to a joint bid/proposal, the Primary Vendor must execute the contract and all Partner Vendors must verify in writing that the Primary Vendor is authorized to represent them in all matters relating to the contract. At least one of the Vendors must have attended any and all mandatory Pre-Proposal or other meetings.

C. Price Schedules

VENDOR is to quote the products and services in accordance with specifications set forth in this Request for Proposal. Prices and other requested data must be stated on or in the exact format of **Cost Schedule C**. Vendors must not modify the format of any Price Schedule or to alter its functionality.

Please Note: You must respond using Schedule C. Failure to do so may result in disqualification of your Proposal. VENDOR shall be responsible for all errors and omissions.

A copy of Cost Schedule C is to be provided in Excel format with your electronic submission. The PDF copy will govern if any discrepancies exist between the PDF copy and electronic version.

D. Pricing Variances

No changes shall be made, nor invoices paid for extra changes, alterations, modifications, deviations, and extra orders except upon a written change order from the UNIVERSITY. The UNIVERSITY will not authorize payment for changes, alterations, modifications, deviations, etc. that are a result of VENDOR error.

E. Certification, Affidavit, and Acknowledgements

The Proposal Certification, Non-Collusion Affidavit, and Vendor Acknowledgements, **Schedule A**, must be executed as a part of the VENDOR'S proposal.

F. Publicity

VENDORS must refrain from giving any reference to this project, whether in the form of press releases, brochures, photographic coverage, or verbal announcements, without written approval from the UNIVERSITY.

G. Freedom of Information Act / non-Confidentiality

Wayne State University is subject to the State of Michigan Freedom of Information Act. As such, proposals may be subject to public review after the contracts have been awarded. VENDORS responding to this proposal are cautioned not to include any proprietary information as part of their proposal.

H. Credit References

From time to time, the University is asked to provide credit and business references to potential new Vendors. In the event your

company is awarded a contract as a result of your response to this RFP, the University would like the option to include your company as a future reference.

I. Insurance Requirements

The University requires Certificates of Insurance per Schedule B for the following types of work: 1) For any and all construction or construction-like work, 2) When work or service is performed on campus, 3) When food is being provided by a private caterer, and 4) When moving services or bus transportation services are being provided. The University reserves the right to require insurance on a case-by-case basis.

When required, VENDORS must indicate in Schedule D that they can meet the insurance requirements found in Schedule B. If awarded a contract, VENDOR must then provide a Certificate of Insurance naming Wayne State University / Office of Risk Management as a certificate holder and the Board of Governors as an additional insured. During the life of the contract, the VENDOR must maintain insurance as stated in Insurance Provisions (Schedule B) and any additional requirements as specified by the UNIVERSITY Office of Risk Management.

For this project, Insurance is **Required**

J. Minority, Woman and Disabled Veteran Owned Business Enterprises (M/W/DBEs)

Specify in your proposal whether ownership of your company is a certified M/W/DVBE. The University, in accordance with guidelines from the MMSDC and WBENC, considers an M/W/DVBE as one that is at least 51% owned, operated, and controlled by an M/W/DVBE, or in case of a publicly owned business, at least 51% of the stock must be owned by an M/W/DVBE.

If the firm is not an M/W/DVBE, describe the firm's partnering relationships (if any) with M/W/DBE and how it plans to support the UNIVERSITY'S goal to award UNIVERSITY business to M/W/DVBEs.

1. Reporting

The selected firm will identify and fairly consider M/W/DVBE for subcontracting opportunities when qualified firms are available to perform a given task in performing for the UNIVERSITY under the resulting agreement. The selected VENDOR must submit a quarterly M/W/DVBE business report to the UNIVERSITY Procurement & Strategic Sourcing by the 15th of the month following each calendar quarter, specifically the months of April, July, October, and January. Such reports should be sent directly to:

Kenneth Doherty, Associate Vice President
Procurement & Strategic Sourcing
Wayne State University
Cohn Nursing Building Classroom Renovation
5700 Cass Avenue, Suite 4200, AAB
Detroit, MI 48202

2. Report Detail

M/W/DVBE business reports must contain, but are not limited to the following:

- Firm's name, address, and phone number with which the VENDOR has contracted over the specified quarterly period
- Contact person at the minority firm who has knowledge of the specified information
- Type of goods and/or services provided over the specified period of time
- Total amount paid to the minority firm as it relates to the UNIVERSITY account.

Specify in your proposal whether your company is a certified 8(A) firm.

A complete set of the University's Supplier Diversity Program, which includes complete definitions of each of the above, can be downloaded from our web site at

http://procurement.wayne.edu/docs/university_policy_2004_02.doc

K. Ownership of Documents

All documents prepared by the VENDOR, including but not limited to: tracings, drawings, estimates, specifications, field notes, investigations,

studies and reports, shall become the property of the UNIVERSITY. At the UNIVERSITY'S option, such documents will be delivered to UNIVERSITY Procurement & Strategic Sourcing. Prior to completion of the contracted services, the UNIVERSITY shall have a recognized proprietary interest in the work product of the VENDOR.

L. WSU Wage Rates

For construction and construction-like work, Wayne State University requires all project contractors, including subcontractors, who provide labor on University projects to compensate at a rate no less than Wayne State University wage rates.

The rates of wages and fringe benefits to be paid to each class of laborers and mechanics by each VENDOR and subcontractor(s) (if any) shall be not less than the wage and fringe benefit rates prevailing in Wayne County, Michigan, as determined by the United States Secretary of Labor. Individually contracted labor commonly referred to as "1099 Workers" and subcontractors using 1099 workers are not acceptable for work on any of Wayne State's properties. Rates for all counties are available at <https://wdolhome.sam.gov/>, and Procurement will post the schedules quarterly that pertain to Wayne County on its website at <http://procurement.wayne.edu/vendors/wage-rates.php>.

Certified Payroll must be provided for each of the contractor's or subcontractor's payroll periods for work performed on any University project. Certified Payroll must accompany Pay Applications, and be fully reconciled with the final Pay Application. Failure to provide certified payroll will constitute a material breach of contract, and pay applications will be returned unpaid, and remain unpaid until satisfactory supporting documents are provided.

Additional information can be found on the University Procurement & Strategic Sourcing's web site at the following URL address: <http://procurement.wayne.edu/vendors/wage-rates.php>.

PROCEDURE

Construction Bids and other Bids or Proposals for work that includes construction shall contain a WSU Wage Rate clause outlining a contractor's responsibilities under University policy. Each bid solicitation shall include reference to the most current wage determination schedule that contractors can use when preparing their bids.

When compensation will be paid under WSU Wage Rate requirements, the University shall require the following:

The contractor shall obtain and keep an accurate record showing the name and occupation of and the actual wages and benefits paid to each laborer and mechanic employed in connection with this contract.

The contractor shall submit a completed certified payroll document [U.S. Department of Labor Form WH 347] verifying and confirming the WSU Wage and benefits rates for all employees and subcontractors for each payroll period for work performed on this project. The certified payroll form can be downloaded from the Department of Labor website at <http://www.dol.gov/whd/forms/wh347.pdf>.

A properly executed sworn statement is required from all tiers of contractors, sub-contractors and suppliers which provide services or product of \$10,000.00 or greater. Sworn statements must accompany applications for payment. All listed parties on a sworn statement as a subcontractor must submit Partial or Full Conditional Waivers for the amounts invoiced on the payment application. A copy of the acceptable WSU Sworn Statement and Waiver will be provided to the awarded contractor.

If the VENDOR or subcontractor fails to pay the WSU rates of wages and fringe benefits and does not cure such failure within 10 days after notice to do so by the UNIVERSITY, the UNIVERSITY shall have the right, at its option, to do any or all of the following:

- Withhold a portion of payments due the VENDOR as may be considered necessary by the UNIVERSITY to pay laborers and mechanics the difference between the rates of wages and fringe benefits required by this contract and the actual wages and fringe benefits paid.
- Terminate the contract and proceed to complete the contract by separate agreement with another vendor or otherwise, in which case the VENDOR and its sureties shall

be liable to the UNIVERSITY for any excess costs incurred by the UNIVERSITY.

- Propose to the Associate Vice President for Business Services / Procurement that the Vendor be considered for Debarment in accordance with the University's Debarment Policy, found on our website at

<https://policies.wayne.edu/appm/2-8-debarment-policy-on-non-responsible-vendor-in-procurement-transactions> .

For more information and a general WSU Wage Rate schedule, see Purchasing Website at:

<http://procurement.wayne.edu/vendors/wage-rates.php>.

M. Buy American

Wayne State University intends to purchase products in the United States of America whenever an American made* product is available that meets or exceeds the specifications requested and the price is equal to or lower than a foreign made product. Vendors are required to bid American made products whenever available. Vendors may bid foreign made products when:

- 1) They are specified
- 2) As an alternate as long as they are technically equal to the product specified.

* (More than 50% of the product is manufactured or assembled in the U.S.A.)

N. Smoke and Tobacco-Free Policies

On August 19, 2015, Wayne State joined hundreds of colleges and universities across the country that have adopted smoke- and tobacco-free policies for indoor and outdoor spaces. Contractors are responsible to ensure that all employees and all subcontractors' employees are in compliance anytime they are on WSU's main, medical, or extension center campuses. The complete policy can be found at <http://wayne.edu/smoke-free/policy/>.

O. Tax Exempt

Wayne State University is a tax-exempt institution. The Vendor shall include in its proposal and make payment of all Federal, State, County and Municipal taxes, including Michigan State Sales and Use Taxes, now in force or which may be enacted during the progress and completion of the work covered. Information regarding the State of Michigan sales and use tax laws related to construction or other similar work can be found in SOM Revenue Administrative Bulletin 2016-18.



Schedule A
Response to Wayne State University
Request for Proposal
RFP: Cohn Nursing Building Classroom Renovation
and any Amendments, Thereto

Dated: July 24, 2024

Proposal Certification, Acknowledgements,
and Non-Collusion Affidavit

VENDOR is to certify its proposal as to its compliance with the Request for Proposal specifications using the language as stated hereon.

ACKNOWLEDGEMENTS

By virtue of submittal of a Proposal, VENDOR acknowledges and agrees that:

- All of the requirements in the Scope of Work of this RFP have been read, understood and accepted.
- The University's General Requirements and Guidelines have been read, understood and accepted.
- Compliance with the Requirements and/or Specifications, General Requirements and Guidelines, and any applicable Supplemental Terms and Conditions will be assumed acceptable to the VENDOR if not otherwise noted in the submittal in an Exhibit I, Restricted Services.
- The Supplier is presently not debarred, suspended, proposed for debarment, declared ineligible, nor voluntarily excluded from covered transactions by any Federal or State of Michigan department or agency.
- Wayne State University is a constitutionally autonomous public university within Michigan's system of public colleges and universities, and as such, is subject to the State of Michigan Freedom of Information Act 442 of 1976. Any Responses Proposals, materials, correspondence, or documents provided to the University are subject to the State of Michigan Freedom of Information Act, and may be released to third parties in compliance with that Act, regardless of notations in the VENDOR's Proposal to the contrary.
- Any contract between the UNIVERSITY and VENDOR resulting from the RFP will be made using the University's Strategic Source Agreement. The Agreement will incorporate this RFP and its terms and conditions and Vendor's Response Proposal by reference. Should the Vendor have additional terms to incorporate into the Agreement, they will be incorporated into the Agreement as an Appendix.
- Upon University request, VENDOR agrees to provide publicly distributed annual reports and/or independently audited financial statements including its statement of financial position, statement of operations, and statement of cash flows for at least the past three years.
- Upon University request, Vendor agrees to permit the UNIVERSITY to audit VENDOR's books, but only as it relates to the Wayne State University account.
- All of the Terms and Conditions of this RFP and Vendor's Response Proposal become part of any ensuing agreement, regardless of whether the ensuing agreement specifically references the RFP and Vendor's Response Proposal.
- The individual signing below has authority to make these commitments on behalf of Supplier.
- This proposal remains in effect for **[120]** days.

VENDOR, through the signature of its agent below, hereby offers to provide the requested products/services at the prices specified, and under the terms and conditions stated and incorporated into this RFP.

PROPOSAL CERTIFICATION

The undersigned, duly authorized to represent the persons, firms and corporations joining and participating in the submission of this Proposal states that the Proposal contained herein is complete and is in strict compliance with the requirements of the subject Request for Proposal dated **July 24, 2024**, except as noted in Exhibit 1, the "**Restricted Services/Exceptions to RFP**" section of the Proposal. If there are no modifications, deviations or exceptions, indicate "None" in the box below:

- NONE** – There are no exceptions to the University's requirements or terms
- YES** – Exceptions exist as shown in Exhibit 1, Restricted Services.



NON-COLLUSION AFFIDAVIT

The undersigned, duly authorized to represent the persons, firms and corporations joining and participating in the submission of the foregoing Proposal, states that to the best of his or her belief and knowledge no person, firm or corporation, nor any person duly representing the same joining and participating in the submission of the foregoing Proposal, has directly or indirectly entered into any agreement or arrangement with any other VENDORS, or with any official of the UNIVERSITY or any employee thereof, or any person, firm or corporation under contract with the UNIVERSITY whereby the VENDOR, in order to induce acceptance of the foregoing Proposal by said UNIVERSITY, has paid or given or is to pay or give to any other VENDOR or to any of the aforementioned persons anything of value whatever, and that the VENDOR has not, directly or indirectly entered into any arrangement or agreement with any other VENDOR or VENDORS which tends to or does lessen or destroy free competition in the letting of the contract sought for by the foregoing Proposal.

The VENDOR hereby certifies that neither it, its officers, partners, owners, providers, representatives, employees and parties in interest, including the affiant, have in any way colluded, conspired, connived or agreed, directly or indirectly, with any other proposer, potential proposer, firm or person, in connection with this solicitation, to submit a collusive or sham bid, to refrain from bidding, to manipulate or ascertain the price(s) of other proposers or potential proposers, or to obtain through any unlawful act an advantage over other proposers or the college.

The prices submitted herein have been arrived at in an entirely independent and lawful manner by the proposer without consultation with other proposers or potential proposers or foreknowledge of the prices to be submitted in response to this solicitation by other proposers or potential proposers on the part of the proposer, its officers, partners, owners, providers, representatives, employees or parties in interest, including the affiant.

CONFLICT OF INTEREST

The undersigned proposer and each person signing on behalf of the proposer certifies, and in the case of a sole proprietorship, partnership or corporation, each party thereto certifies as to its own organization, under penalty of perjury, that to the best of their knowledge and belief, no member of the UNIVERSITY, nor any employee, or person, whose salary is payable in whole or in part by the UNIVERSITY, has a direct or indirect financial interest in the award of this Proposal, or in the services to which this Proposal relates, or in any of the profits, real or potential, thereof, except as noted otherwise herein.

Any notice required under the Agreement shall be personally delivered or mailed by first class or certified mail, with proper postage, prepaid, to the Subject VENDOR at the following address:

Company Name: _____

Address: _____

Telephone: (_____) _____

Email address: _____

Submitted by: _____

Signature _____

(Title)

(Date)

Schedule B

Insurance Requirements (Rev 8-2023)

For this project, Insurance is **Required**

The Vendor, at its sole expense, shall cause to be issued and maintained in full effect for the term of this agreement, insurance as set forth hereunder:

<u>Type of Insurance</u>	<u>General Requirements</u>	<u>Minimum Requirement</u>
1. Commercial General Liability (CGL) CGL insurance should be written on ISO form CG 00 01 (or equivalent substitute)		\$1,000,000 combined single limit \$2,000,000 annual aggregate
2. Professional Liability		\$2,000,000 combined single limit \$2,000,000 annual aggregate
3. Excess Liability (Umbrella)		\$5,000,000 per occurrence
4. Commercial Automobile Liability (including hired and non-owned vehicles)		\$1,000,000 combined single limit per accident for bodily injury and property damage, without annual aggregate.
5. Workers' Compensation (Employers' Liability)		Required by the State of Michigan and Employer's Liability in the amount of \$1,000,000 per accident for bodily injury or disease.

Maximum Acceptable Deductibles

<u>Type of Insurance</u>	<u>Deductible</u>
Commercial General Liability	\$5,000
Commercial Automobile Liability	0
Workers' Compensation	0
Property - All Risk	\$1,000

Coverage

1. All liability policies must be written on an occurrence form of coverage.
2. Commercial General Liability (CGL) includes, but is not limited to: consumption or use of products, existence of equipment or machines on location, and contractual obligations to customers.
3. The Board of Governors of Wayne State University shall be named as an additional insured, but only with respect to accidents arising out of said contract.
4. The additional insured provision shall contain a cross liability clause as follows: "The insurance afforded applies separately to each insured against whose claim is made or suit is brought, except with respects to the limits of the company's liability."
5. The insurance company for each line of insurance coverage will be reviewed and checked per the A.M. Best's Key Rating Guide. **A rating of not less than "A-" is required**

Certificates of Insurance

1. Certificates of Insurance naming Wayne State University / Office of Risk Management as the certificate holder and stating the minimum required coverage must be forwarded to the Office of Risk Management to be verified and authenticated with the agent and/or insurance company.
2. Certificates shall contain a statement from the insurer that, for this contract, the care, and custody or control exclusion is waived.
3. Certificates shall be issued on a ACORD form or one containing the equivalent wording, and require giving WSU a thirty (30) day written notice of cancellation or material change prior to the normal expiration of coverage.
4. Revised certificates must be forwarded to the Office of Risk Management thirty (30) days prior to the expiration of any insurance coverage listed on the original certificate, as follows:

Wayne State University
Office of Risk Management
5700 Cass Avenue, Suite 4622 AAB
Detroit, MI 48202

Specific Requirements- Individual contracts may require coverage in addition to the minimum general requirement such as, business interruption, higher limits and or blanket fidelity insurance.

Schedule B

Exception to the insurance requirements is to be approved, in writing, by the Office of Risk Management. Exceptions are determined by the type and nature of the contract and the individual contractor.

Schedule B



CERTIFICATE OF LIABILITY INSURANCE

DATE (MM/DD/YYYY)

THIS CERTIFICATE IS ISSUED AS A MATTER OF INFORMATION ONLY AND CONFERS NO RIGHTS UPON THE CERTIFICATE HOLDER. THIS CERTIFICATE DOES NOT AFFIRMATIVELY OR NEGATIVELY AMEND, EXTEND OR ALTER THE COVERAGE AFFORDED BY THE POLICIES BELOW. THIS CERTIFICATE OF INSURANCE DOES NOT CONSTITUTE A CONTRACT BETWEEN THE ISSUING INSURER(S), AUTHORIZED REPRESENTATIVE OR PRODUCER, AND THE CERTIFICATE HOLDER.

IMPORTANT: If the certificate holder is an ADDITIONAL INSURED, the policy(ies) must be endorsed. If SUBROGATION IS WAIVED, subject to the terms and conditions of the policy, certain policies may require an endorsement. A statement on this certificate does not confer rights to the certificate holder in lieu of such endorsement(s).

PRODUCER	CONTACT NAME:		
	PHONE (A/C, No, Ext):	FAX (A/C, No):	
INSURED	E-MAIL ADDRESS:		
	INSURER(A) AFFORDING COVERAGE		NAIC #
	INSURER A:		
	INSURER B:		
	INSURER C:		
	INSURER D:		
	INSURER E:		
	INSURER F:		

COVERAGES CERTIFICATE NUMBER: REVISION NUMBER:

THIS IS TO CERTIFY THAT THE POLICIES OF INSURANCE LISTED BELOW HAVE BEEN ISSUED TO THE INSURED NAMED ABOVE FOR THE POLICY PERIOD INDICATED. NOTWITHSTANDING ANY REQUIREMENT, TERM OR CONDITION OF ANY CONTRACT OR OTHER DOCUMENT WITH RESPECT TO WHICH THIS CERTIFICATE MAY BE ISSUED OR MAY PERTAIN, THE INSURANCE AFFORDED BY THE POLICIES DESCRIBED HEREIN IS SUBJECT TO ALL THE TERMS, EXCLUSIONS AND CONDITIONS OF SUCH POLICIES. LIMITS SHOWN MAY HAVE BEEN REDUCED BY PAID CLAIMS.

INSR LTR	TYPE OF INSURANCE	ADDL INSD	SUBR WVD	POLICY NUMBER	POLICY EFF (MMDD/YYYY)	POLICY EXP (MMDD/YYYY)	LIMITS
	COMMERCIAL GENERAL LIABILITY <input type="checkbox"/> CLAIMS-MADE <input type="checkbox"/> OCCUR GEN'L AGGREGATE LIMIT APPLIES PER: <input type="checkbox"/> POLICY <input type="checkbox"/> PRO-JECT <input type="checkbox"/> LOC OTHER:						EACH OCCURRENCE \$ \$1,000,000 DAMAGE TO RENTED PREMISES (Ea occurrence) \$ MED EXP (Any one person) \$ PERSONAL & ADV INJURY \$ GENERAL AGGREGATE \$ \$2,000,000 PRODUCTS - COMP/OP AGG \$ OTHER \$
	AUTOMOBILE LIABILITY <input type="checkbox"/> ANY AUTO <input type="checkbox"/> ALL OWNED AUTOS <input type="checkbox"/> SCHEDULED AUTOS <input type="checkbox"/> HIRED AUTOS <input type="checkbox"/> NON-OWNED AUTOS						COMBINED SINGLE LIMIT (Ea accident) \$ \$1,000,000 BODILY INJURY (Per person) \$ BODILY INJURY (Per accident) \$ PROPERTY DAMAGE (Per accident) \$ OTHER \$
	<input type="checkbox"/> UMBRELLA LIAB <input type="checkbox"/> OCCUR <input type="checkbox"/> EXCESS LIAB <input type="checkbox"/> CLAIMS-MADE DED RETENTION \$						EACH OCCURRENCE \$ AGGREGATE \$ OTHER \$
	WORKERS COMPENSATION AND EMPLOYERS' LIABILITY ANY PROPRIETOR/PARTNER/EXECUTIVE OFFICER/MEMBER EXCLUDED? (Mandatory in NH) If yes, describe under DESCRIPTION OF OPERATIONS below						PER STATUTE <input checked="" type="checkbox"/> OTH-ER <input type="checkbox"/> State of Michigan E.L. EACH ACCIDENT \$ E.L. DISEASE - EA EMPLOYEE \$ E.L. DISEASE - POLICY LIMIT \$

WSU Requires This

WSU Requires This

WSU Requires This

DESCRIPTION OF OPERATIONS / LOCATIONS / VEHICLES (ACORD 101, Additional Remarks Schedule, may be attached if more space is required)

The Board of Governors of Wayne State University shall be named as an additional insured, but only with respect to accidents arising out of said contract

CERTIFICATE HOLDER Wayne State University Enterprise Risk Management & Insurance Programs 5700 Cass Avenue, Suite 4622 AAB Detroit, MI 48202	CANCELLATION SHOULD ANY OF THE ABOVE DESCRIBED POLICIES BE CANCELLED BEFORE THE EXPIRATION DATE THEREOF, NOTICE WILL BE DELIVERED IN ACCORDANCE WITH THE POLICY PROVISIONS. AUTHORIZED REPRESENTATIVE
---	--



WAYNE STATE
UNIVERSITY

Schedule C

(Cost Schedule; Compensation and Fees)

See website:

<http://go.wayne.edu/bids>



SCHEDULE D - SUMMARY QUESTIONNAIRE (2 PAGES)

- | | YES | ALTERNATIVE |
|--|---------------------------------|-----------------|
| 1. Can your company commence on or before November 2024 and be completed by December 20, 2024? | _____ | _____ |
| 2. Did you attend the Optional Pre-Proposal meeting on July 31, 2024? | _____ | _____ |
| 3. Did your company provide the required Proposal Certification, Non- Collusion Affidavit and Vendor Acknowledgement, Schedule A? | _____ | _____ |
| 4. If awarded a contract, will your company provide a certificate of insurance to meet or exceed all our minimum requirements as outlined in Schedule B? | _____ | Required |
| 5. Did your company complete and provide the Summary Price Schedule C , and submit it electronically? (Zip Files are not acceptable) | _____ | _____ |
| 6. Please complete the following:

Total number of employees in your company

Year your company was incorporated (year founded) | _____

_____ | |
| 7. Are you or any Officer, Owner or Partner in this company an employee of Wayne State University, or have you been an employee within the past 24 months? If Yes, explain in Exhibit 1. | ___ Yes
___ No | |
| 8. Are any family members of any Officer, Owner or Partner in this company employees of Wayne State University? If Yes, explain in Exhibit 1. | ___ Yes
___ No | |
| 9. Did your company provide any exceptions or restricted services as an Exhibit 1? | ___ Yes
___ No | |
| 10. For any construction or installation work, did your company quote services at WSU Wage Rates and clearly indicate such in your proposal? | _____ | _____ |

11. ADDENDA:

The undersigned affirms that the cost of all work covered by the following Addenda are taken into consideration when providing price and other elements of the vendor's proposal.

Addendum No. _____ Date _____	Addendum No. _____ Date _____
Addendum No. _____ Date _____	Addendum No. _____ Date _____
Addendum No. _____ Date _____	Addendum No. _____ Date _____



WAYNE STATE UNIVERSITY

12. Does your company agree to provide a list of lost accounts in excess of \$25,000, if any?
13. Does your company agree to provide a minimum of 3 references to the University upon request, with specific contact names and phone numbers?
14. Does your company agree to comply with the University Smoke and Tobacco Free Policies?
15. If awarded an agreement as a result of this RFP, is your company willing to serve as a future credit reference for the University?

_____	_____
_____	_____
_____	_____
_____	_____

Company Name: _____

Address: _____

Telephone: (_____) _____

Email address: _____

Submitted by: _____

Signature _____

_____ (Title) _____ (Date)



APPENDIX 1

(Wayne State University Campus Map)

See web site:

<http://campusmap.wayne.edu/>

**A detailed list of Cash & Coin operated lots can be viewed at
http://procurement.wayne.edu/cash_and_credit_card_lots.php**



APPENDIX 2

New Vendor Set-Up Requirements

If you are a potential new supplier to the University, thank you for your interest in doing business with the Wayne State. The first step will be for you to register on the Wayne State University Supplier/Vendor Registration portal for Businesses and Non-Employee Individual Payees.

If you're an existing supplier to the University, simply disregard the information below.

The supplier database is used for all external payments and to qualify potential U.S. Based suppliers, so these suppliers may be invited to participate in Wayne State University future sourcing/bid selection processes for various products and services. The process should take 15 minutes or less to complete. Before beginning, please have handy a PDF copy of your current W9, insurance certificate (if applicable), and any certifications, such as supplier diversity certifications.

The process is a two-step process. At step one, you'll be asked for your name, company name, and email address. Our system will validate the email domain, and upon validation, will return an email with a separate link to complete the process. You'll navigate through 9 separate screens:

1. Welcome
2. Company or Individual Overview
3. Addresses
4. Contacts
5. Insurance (if applicable)
6. Payment Information
7. Tax Information
8. Conflict of Interest information
9. Certify & Submit

The link for Domestic (U.S. Based) vendors to self-register via our new supplier portal found at <https://solutions.sciquest.com/apps/Router/SupplierLogin?CustOrg=WayneState>

** Foreign Vendors: Please complete the PDF writable vendor registration form [New Vendor Request - Businesses](#) and email it to purchasingdocs@wayne.edu for registration. Be sure to include the appropriate IRS W-8 **

Suppliers with a Disability If you need accessibility assistance or to request our Procurement Personnel to register your company, please contact the Procurement Team at purchasingdocs@wayne.edu



**WAYNE STATE
UNIVERSITY**

APPENDIX 3

WSU WAGE RATES

(POSTED SEPARATELY)

See web site:

<http://go.wayne.edu/bids>



WAYNE STATE
UNIVERSITY

APPENDIX 4

DRAWINGS

See web site:

<http://go.wayne.edu/bids>



WAYNE STATE
UNIVERSITY

APPENDIX 5

WAYNE STATE UNIVERSITY STRATEGIC SOURCE AGREEMENT



WAYNE STATE UNIVERSITY

STRATEGIC SOURCE AGREEMENT

This Agreement, effective as of the date of the last signature of the authorized representatives (the "Effective Date"), is made by and between Wayne State University, 5700 Cass Avenue, suite 4200, Detroit, Michigan 48202, a constitutional body corporate of the State of Michigan ("University") and, **(Supplier_Name)**, **(Supplier_Address)**, **(Supplier_City_State_Zip)**, ("the Supplier")

For good and valuable consideration, the parties agree as follows:

- 1. General Purpose:** The general purpose of this Agreement is to engage the services of the Supplier to provide **(Named_Services)** (**Services**), per the University Request for Proposal dated **(Quote_Date)** (the RFP) and the Supplier's response Proposal dated **(Bid_Date)**, and the Price Schedule attached as Exhibit C. The University has assigned **(Project_Manager)** as the Contract Administrator. Only contract directives from the University's Procurement and Strategic Sourcing Department or the Contract Administrator shall be accepted by the Supplier. The Procurement contact for this agreement is **Valerie Kreher**, email; **rfpteam2@wayne.edu**.
- 2. General Duties of the Supplier:** The Supplier shall provide the University with **(Named_Services)** of superior quality, at competitive pricing, as described in the Statement of Work section of the RFP, which is incorporated by reference into this Agreement. The Supplier agrees to perform such professional services with the standard of professional care and skill customarily provided in the performance of such services. The supplier agrees to perform these services to the reasonable satisfaction of the University during the term of this Agreement.
- 3. Term:** The contract period shall be for an initial time-period commencing on the date of the last signature of the authorized representatives, and shall continue through **(Contract_End_Date)** (the "Initial Term"), with the option to renew for up to two additional one-year periods of Services (each a "Renewal Term" and together with the Initial Term, the "Term"), through **(Extension_Date)**. Renewal is contingent upon both parties agreeing in writing to do so, based on satisfaction of the price and the Supplier's performance.
- 4. The Roles and Responsibilities (Scope of Work):**
The roles and responsibilities of the Supplier are listed in Exhibit A of this agreement.
- 5. Wayne State University Wage Rates:** For construction and construction-like work, Wayne State University requires all project contractors, including subcontractors, who provide labor on University projects to compensate at a rate no less than Davis Bacon Wage Determinations (WSU Wage Rates). This includes, but is not limited to new construction, building renovation, and installation of furniture or equipment where a construction trade is used (i.e. installation of audiovisual equipment or furniture requiring electrical or carpentry work). The complete policy regarding WSU Wage Rates can be found at <https://policies.wayne.edu/appm/2-10-prevailing-wage-construction>.
- 6. Customer Support:** The Supplier shall have a primary point of contact for the University community. The contact shall be accessible during normal business hours of every business day, 8:00 am to 5:00 pm (Eastern Time).
- 7. Business Review Meetings:** In order to maintain the partnership between the University and the Supplier, the University requires regular Business Review meetings. Meetings shall be held on at least an annual basis, or more frequently upon University request. The business review meeting shall include, but not be limited to, the following:
 - Review of Supplier performance as demonstrated in supplier scorecards
 - Review of minimum required reports (see Section 8 below)
 - Review of continuous improvement plans

Frequency of Business Review meetings will be defined at the end of the Initial Term by mutual agreement.

- 8. Reports:** The Supplier will submit applicable monthly and quarterly usage reports, in the format specified below, to the Procurement and Strategic Sourcing Department, which details the usage during the reporting period. Reports are to be submitted to **(Project_Manager)** as listed below:

Monthly and Year-to Date (YTD) reports are required to be received in an excel format, no later than the 6th of the month following activity, and must include the following information:

Reports & Statistics

- Quantity and total value of all product being sold & installed
- Total value of tier 2 purchases obtained from Diverse Businesses (M/W/DBE)
- _____
- _____

Upon reasonable request, additional ad hoc reports must be prepared and made available to the University.

- Purchase Orders:** Orders will be placed for goods, services or projects as the need arises, or will be issued as blanket orders for each individual fiscal year. Each order will be placed on a University Purchase Order generated through our WayneBuy system. All subsequent invoices, packing tickets, and other correspondence related to the individual order are to include the unique PO number.
- Invoicing:** Deliveries or services shall be invoiced on an individual basis and shall be due thirty (30) days after University's receipt and approval of invoice. The invoices must reference the PO number and be submitted to the University's Accounts Payable department via email address: wsuinvoices@wayne.edu.
- ACH Payments:** ACH payments are both faster and less costly for Suppliers and the University. As a result, this is the University's preferred payment method. The Supplier is expected to enroll in the University's ACH program. The ACH payment agreement form can be downloaded at https://disbursements.wayne.edu/files/ach_payment_agreement_form.pdf. The completed form should be digitally signed or signed & scanned, and sent to vendorach@wayne.edu.
- Tax Exempt:** Wayne State University is a tax-exempt institution. The Supplier shall include in its proposal and make payment of all Federal, State, County and Municipal taxes, including Michigan State Sales and Use Taxes, now in force or which may be enacted during the progress and completion of the work covered. Information regarding the State of Michigan sales and use tax laws related to construction or other similar work can be found in SOM Revenue Administrative Bulletin 2016-18.
- eProcurement Requirements:** The University has implemented an eProcurement platform. The Supplier will work in close cooperation with the Procurement Department to adapt to the eProcurement program as required by the University.
- Annual Price Increases:** All prices quoted must be firm through September 30, 20___. If a price increase is required at the end of periods two or three, the Supplier must have their request in writing to the Commodity Manager no later than July 31 of the preceding term. Price increases must be justified by citing the appropriate market indices. Price increases will be reviewed and either accepted or rejected in writing.
- Confidentiality of Information:** The Supplier agrees to keep confidential and not to disclose to third parties any information provided by the University pursuant to this Agreement unless the Supplier has received prior written consent of the University to make such disclosure. This obligation of confidentiality does not extend to any information that:
 - Was in the possession of the Supplier at the time of disclosure by the University, directly or indirectly;
 - Is or has become, through no fault of the Supplier, available to the general public; or
 - Is independently developed and hereafter supplied to the Supplier by a third party without restriction on disclosure. The provisions of this Section 14 shall survive expiration and termination of this Agreement.

The Supplier is required to sign the University Confidentiality and Non-Disclosure Agreement. A copy of the Agreement can be found in Exhibit B. If the Supplier is not an individual, the Supplier represents and warrants that it has the authority to bind each of its employees, officers, agents, representatives and consultants to the terms of the Agreement. The Supplier shall be responsible for ensuring such personnel are aware of and comply with all obligations imposed by this Confidentiality and Non-Disclosure Agreement.

- Independent Contractor:** The parties expressly acknowledge that the Supplier is an independent contractor. The Supplier is not an agent, partner, or employee of the University. The Supplier shall not have the authority to enter into any contract or agreement to bind the University and shall not represent to anyone that the Supplier has such authority. The Supplier represents and warrants to the University that in performing the Services hereunder, the Supplier will not be in breach of any agreement with a third party. The Supplier declares that it is not a Legislator, elected or appointed officer, or that its firm is not owned or controlled by any Legislator, elected or appointed officer, compensated or uncompensated, member of a State board or commission, or other employee of the State of Michigan (including an employee, officer, or official of Wayne State University). The Supplier agrees that he/she is subject to the University's regulations, laws of the United States and of the State of Michigan, and that, in the event of violation of these, or behavior that is considered to be detrimental to the University or its students, faculty or staff, the University shall have the right to terminate the agreement without prior notice.
- Property Rights and Reports:** The Supplier agrees that any computer programs, software, documentation, copyrightable work, discoveries, inventions, improvements, or other products developed by the Supplier solely, or with others, resulting from the performance of this Agreement are the property of the University, and the Supplier assigns all rights therein to the University. The Supplier further agrees to provide the University with any assistance which the University may require to obtain patents or

copyright registrations, including the execution of any documents submitted by the University. This provision shall survive expiration and termination of this Agreement.

18. **Indemnification and Hold Harmless:** The **Supplier** agrees that any personal injury to the Supplier or third parties or any property damage incurred in the course of performance of this Agreement that are not the result of any act or omission on the part of the University shall be the responsibility of the Supplier. The Supplier agrees to indemnify, defend, and hold harmless the University, its governing board, officers, employees, agents, and students from and against any and all costs, losses, damages, liabilities, expenses, demands, and judgments, including court costs and attorneys' fees, whether for personal injury or property damage, infringement of any third party intellectual property right, or any other claim, which may arise out of the Supplier's performance of this Agreement whether caused in whole or in part by the Supplier or anyone for whom the Supplier is responsible, regardless of whether or not it is caused in part by the University.
 19. **Non-Discrimination:** The parties agree that in the performance of any contract they shall not discriminate in any manner on the basis of race, creed, color, national origin, age, religion, sex, sexual orientation, marital status or handicap protected by law. Such action shall include, but is not limited to the following: employment, upgrading, demotion, transfer, recruitment or recruitment advertising; layoff or termination; rates of pay or other forms of compensation. The **Supplier** certifies that they will conform to the provisions of the Federal Civil Rights Action of 1964, as amended. Information on the Civil Rights Act can be found at <http://www.eeoc.gov/laws/statutes/titlevii.cfm>
 20. **Civil Rights Requirements:** The **Supplier** must be in compliance with the directives of the Michigan Department of Civil Rights. The Department of Civil Rights web address is <http://www.michigan.gov/mdcs/0,1607,7-147-6881---,00.html>
 21. **Immigration Reform and Control Act of 1986:** The **Supplier** certifies that they do not and will not during the performance of this contract employ illegal alien workers or otherwise violate the provisions of the federal Immigration Reform and Control Act of 1986.
 22. **Debarment Status:** The **Supplier** certifies that they are not currently debarred from submitting bids on contracts nor are they an agent of any person or entity that is currently debarred from submitting bids on contracts. The University's Department Policy can be found at <https://policies.wayne.edu/appm/2-8-debarment-policy-on-non-responsible-vendor-in-procurement-transactions>. State of Michigan information on Debarment can be found at <http://www.michigan.gov/buymichiganfirst/0,1607,7-225-48677-20042--,00.html>. The Federal Debarred Vendor List (Excluded Parties List System) and related links searched at <https://www.dol.gov/agencies/ofccp/debarred-list>
 23. **Supplier Liability:** The **Supplier** will be liable for any associated costs of repairs for damage to buildings or other UNIVERSITY property caused by the negligence of the Supplier's employees.
 24. **Early Termination by the University:** The UNIVERSITY shall have the right to terminate the contract with the **Supplier** without penalty after the UNIVERSITY'S thirty (30) days written notice of termination to the **Supplier** under the following circumstances:
 1. **Default of Supplier**

It shall be considered a default whenever the **Supplier** shall:

 - a. Disregard or violate material provisions of the contract documents or UNIVERSITY instructions, or fail to execute the work according to the agreed upon schedule of completion and/or time of completion specified, including extensions thereof, or fail to reach agreed upon performance results.
 - b. Declare bankruptcy, become insolvent, or assign company assets for the benefit of creditors.
 2. **Convenience of the UNIVERSITY**

When termination of the contract is determined to be in the best interest of the University for serving it's community, and its students, faculty, and staff.
- Note:** Any contract cancellation notice shall not relieve the SUPPLIER of the obligation to deliver and/or perform prior to the effective date of cancellation.

25. **Cancellation of Contract by the Supplier:** The Supplier must provide a minimum of ninety (90) days written notice of cancellation of contract to the UNIVERSITY regardless of the reason for said termination. Such notification must be sent to:

Kenneth Doherty, Associate Vice President
Procurement & Business Services
Wayne State University
RFP: Cohn Nursing Building Classroom Renovation
5700 Cass Avenue, Suite 4200, AAB

Detroit, MI 48202

26. **Notice:** Any notice to either party hereunder must be in writing signed by the party giving it and shall be served either personally or by registered or certified mail addressed as follows:

To the University:
Wayne State University
Kenneth Doherty, Associate VP
Procurement & Strategic Sourcing
5700 Cass Avenue, Suite 4200
Detroit, MI, 48202

To the Supplier:
(Supplier_Name)
(Supplier Representative)
(Representative_Title)
(Supplier_Address), (Supplier_City_State_Zip)

The above notification addresses as may be modified by either party during the agreement, only by written notice. All such notices shall be effective only when received by the addressee.

27. **Entire Agreement:** This Agreement and its exhibits, along with the RFP dated **(Quote_Date)** and the Supplier's Proposal dated **(Bid_Date)** (and its attachments, if any), and subsequent clarifications and addenda, constitute the entire agreement between the parties with respect to the subject matter hereof and may not be amended except by a written agreement signed by the Supplier and an authorized representative of the University. The terms of this Agreement shall prevail over any conflicting terms of the RFP and Supplier's Proposal to the extent that there is a conflict. Said terms govern and supersede the standard terms and conditions of individual Purchase Orders, regardless of whether said Purchase Orders specifically reference back to this Agreement.
28. **Modification of Service:** The UNIVERSITY reserves the right to modify the services during the course of the contract, with concurrence of the **Supplier**. Any changes in pricing and rates proposed by the **Supplier** resulting from such changes are subject to acceptance by the UNIVERSITY.
- In the event prices and rates cannot be negotiated to the satisfaction of both parties, the contract may be subject to cancellation and competitive bidding based upon the new specifications.
29. **Severability:** The terms of this Agreement are severable such that if any term or provision is declared by a court of competent jurisdiction to be illegal, void, or unenforceable, the remainder of the provisions shall continue to be valid and enforceable.
30. **Governing Law and Compliance:** This Agreement shall be governed by and construed under the laws of the State of Michigan, without regard to its choice of law rules. Any lawsuits arising from or incident to this Agreement shall be brought in the Michigan Court of Claims. Each party will be individually responsible for compliance with all laws, including anti-discrimination laws, which may be applicable to their respective activities under this Agreement.
31. **Non-Waiver:** The delay or failure of either party to exercise any of its rights under this Agreement for a breach thereof shall not be deemed to be a waiver of such rights, nor shall the same be deemed to be a waiver of any subsequent breach, either of the same provision or otherwise.
32. **Non-Assignment:** The agreement shall be between the UNIVERSITY and the **Supplier**, and the **Supplier** shall neither assign nor delegate the agreement, its rights or obligations, or any of its terms without the express written permission of the UNIVERSITY.
33. **Authority:** The parties warrant that they have the authority to enter into this Agreement and that entering into this Agreement is not restricted or prohibited by any existing agreement to which they are parties.
34. **Non-Exclusivity:** This Agreement does not create an exclusive relationship between Wayne State University and the Supplier. The University reserves the right to use other service providers, in the event it is determined to be in the best interest of the University, its employees, students, or staff.
35. **Credit References:** From time to time, the University is asked to provide credit and business references to potential new Suppliers. Company agrees that it will serve as a Credit Reference for the University with respect to the amount and timeliness of payments.
36. **Financial Reports:** Upon University request, the Supplier must provide publicly distributed annual reports and/or independently audited financial statements including its statement of financial position, statement of operations, and statement of cash flows.
37. **Right to Audit:** Supplier must further agree to permit the UNIVERSITY, upon request, to audit SUPPLIER's books, but only as it relates to the Wayne State University account, including invoicing, operational, and technology controls (when applicable). The University is limited to 1 request per calendar year of this agreement.

38. Insurance:

INSURANCE REQUIREMENTS (Rev 2-2015)

The Supplier, at its sole expense, shall cause to be issued and maintained in full effect for the term of this Agreement, insurance as set forth hereunder:

General Requirements

Type of Insurance

Minimum Requirement

- | | |
|--|---|
| <ol style="list-style-type: none"> 1. Commercial General Liability (CGL)
CGL insurance should be written on ISO form CG 00 01 (or equivalent substitute) <p>Contracts valued at \$100,000 per year or more</p> <ol style="list-style-type: none"> 2. Commercial Automobile Liability (including hired and non-owned vehicles) 3. Workers' Compensation (Employers' Liability) | <p>\$1,000,000 combined single limit
\$2,000,000 annual aggregate</p> <p>Umbrella Liability per occurrence and in the annual aggregate of \$5,000,000.</p> <p>\$1,000,000 combined single limit per accident for bodily injury and property damage, without annual aggregate.</p> <p>Required by the State of Michigan and Employer's Liability in the amount of \$500,000 per accident for bodily injury or disease.</p> |
|--|---|

Maximum Acceptable Deductibles

Type of Insurance

Deductible

- | | |
|---|--|
| <p>Comprehensive General Liability
Comprehensive Automobile Liability
Workers' Compensation
Property - All Risk</p> | <p>\$5,000
0
0
\$1,000</p> |
|---|--|

Coverage

1. All liability policies must be written on an occurrence form of coverage.
2. Commercial General Liability (CGL) includes, but is not limited to: personal injury, property damage, consumption or use of products, existence of equipment or machines on location, and contractual obligations to customers.
3. The Board of Governors of Wayne State University shall be named as an additional insured, but only with respect to accidents arising out of said contract, on any of Supplier's or its subcontractors' insurance policies.
4. The additional insured provision shall contain a cross liability clause as follows: "The insurance afforded applies separately to each insured against whose claim is made or suit is brought, except with respects to the limits of the company's liability."
5. The insurance company for each line of insurance coverage will be reviewed and checked per the A.M. Best's Key Rating Guide. **A rating of not less than "A-" is required.**

Certificates of Insurance

1. Certificates of Insurance naming Wayne State University / Office of Risk Management as the certificate holder and stating the minimum required coverage must be forwarded to the Office of Risk Management to be verified and authenticated with the agent and/or insurance company.
2. Certificates shall contain a statement from the insurer that, for this contract, the care, custody, or control exclusion is waived.
3. Certificates shall be issued on a ACORD form or one containing the equivalent wording, and require giving WSU a thirty (30) day written notice of cancellation or material change prior to the normal expiration of coverage.
4. Revised certificates must be forwarded to the Office of Risk Management thirty (30) days prior to the expiration of any insurance coverage listed on the original certificate, as follows:

Wayne State University
Office of Risk Management
5700 Cass Avenue, Suite 4622 AAB
Detroit, MI 48202

Specific Requirements- Individual contracts may require coverage in addition to the minimum general requirement such as, business interruption, higher limits and or blanket fidelity insurance.

Exception to the insurance requirements is to be approved, in writing, by the Office of Risk Management. Exceptions are determined by the type and nature of the contract and the individual contractor.

IN WITNESS WHEREOF, the authorized representatives of the parties have executed this Agreement on **(Contract_Date)**.

Wayne State University

Signature: _____

Name: Kenneth Doherty, CPSM

Title: Associate Vice President – Procurement

Date: _____

Phone: 313-577-3756

email: ac0578@wayne.edu

(Supplier Name)

Signature: _____

Name: _____

Title: _____

Date: _____

Phone: _____

email: _____

Wayne State University

Signature: _____

Name: Bethany Gielczyk

Title: Interim Senior Vice President Business Affairs; Chief Financial Officer; Treasurer

Date: _____

Phone: 313-577-5426

email: BGielczyk@wayne.edu

Sample

EXHIBIT A

Roles & Responsibilities

The roles and responsibilities of the Supplier are listed below.
(Scope_of_Work)

Sample



EXHIBIT B

Confidentiality and Non-Disclosure Agreement

Wayne State University, hereafter referred to as "University", has contracted with **(Supplier Name)**, hereafter referred to as "The Supplier" to supply **(Named Services)** and related services to the University as defined in and pursuant to the Strategic Source Agreement ("Agreement") between the parties. As part of this Agreement, the undersigned agrees to the terms of this Confidentiality and Non-Disclosure Agreement (the "NDA") as follows:

1) Confidential Information

For the purposes of this NDA the term "Confidential Information" shall mean any non-public, proprietary or confidential information received by the Supplier, from the University, in the course of providing services as described above, including but not limited to:

- (i) any and all technical and business information of the University and
- (ii) information from third parties related to health care services and research; provided, however, that Confidential Information does not include any information that:
 - (a) was in the possession of the Supplier at the time of disclosure by the University, directly or indirectly,
 - (b) is or has become, through no fault of the Supplier, available to the general public or
 - (c) is independently developed and hereafter supplied to the Supplier by a third party without restriction on disclosure.

2) Use of Information

The undersigned hereby agrees not to use Confidential Information for any purpose except in the performance of services as described above.

3) Reproduction of Materials

The undersigned will not retain or transfer any programming, documentation, or any other University controlled or provided software or other materials. No such materials may be copied or reproduced without the University's express prior written consent, and any copies made shall become the property of the University.

4) Confidentiality

The undersigned agrees to maintain the confidentiality of the Confidential Information, programs, documentation, and any related materials. The undersigned will not share any information regarding the Confidential Information, programs, documentation, and any related materials with any third party, subcontractor, or independent vendor unless expressly given permission in writing by an authorized University official.

5) No Waiver

Nothing in this NDA shall be construed to limit or otherwise reduce the University's rights to enforce its terms. No delay or forbearance by the University in enforcing any rights set forth in this NDA shall be construed to operate as a waiver of such rights.

6) Supplier Employees and Agents

The Supplier represents and warrants that it has the authority to bind each of its employees, officers, agents, representatives and consultants to the terms of the Agreement. The Supplier shall be responsible for ensuring such personnel are aware of and comply with all obligations imposed by this NDA.

7) Breach of Contract

Any breach of this NDA by the Supplier and/or any of its officers, agents, employees, representatives and/or consultants shall be considered a material breach of the Service Provider Agreement or individual Purchase Order. The Supplier and each of its officers, agents, employees, representatives and/or consultants shall be both jointly and individually liable to the University for any Damages as a result of any breach of this NDA.

The Supplier acknowledges and agrees that a breach of this NDA may cause continuing and irreparable injury to the University as a direct result of any such violation, for which the remedies at law may be inadequate, and that the University shall therefore be entitled, in the event of any actual or threatened violation of the NDA by the Supplier, and in addition to any other remedies available to it, to a temporary restraining order and to injunctive relief against the Supplier or the undersigned to prevent any violations thereof, and to any other appropriate equitable relief.

8) Governing Law, Modification

This NDA shall be governed by and construed under the laws (other than the choice or conflict of law provisions) of the State of Michigan. Any legal action arising out of or relating to this NDA shall be brought in the Michigan Court of Claims. The provisions of this NDA may not be amended except in a writing signed on behalf of each party.

The undersigned agrees to the specific terms expressed in this NDA.

_____	()
Name	Telephone
_____	(Supplier Name)
Title	Company
_____	_____
Signature	Date

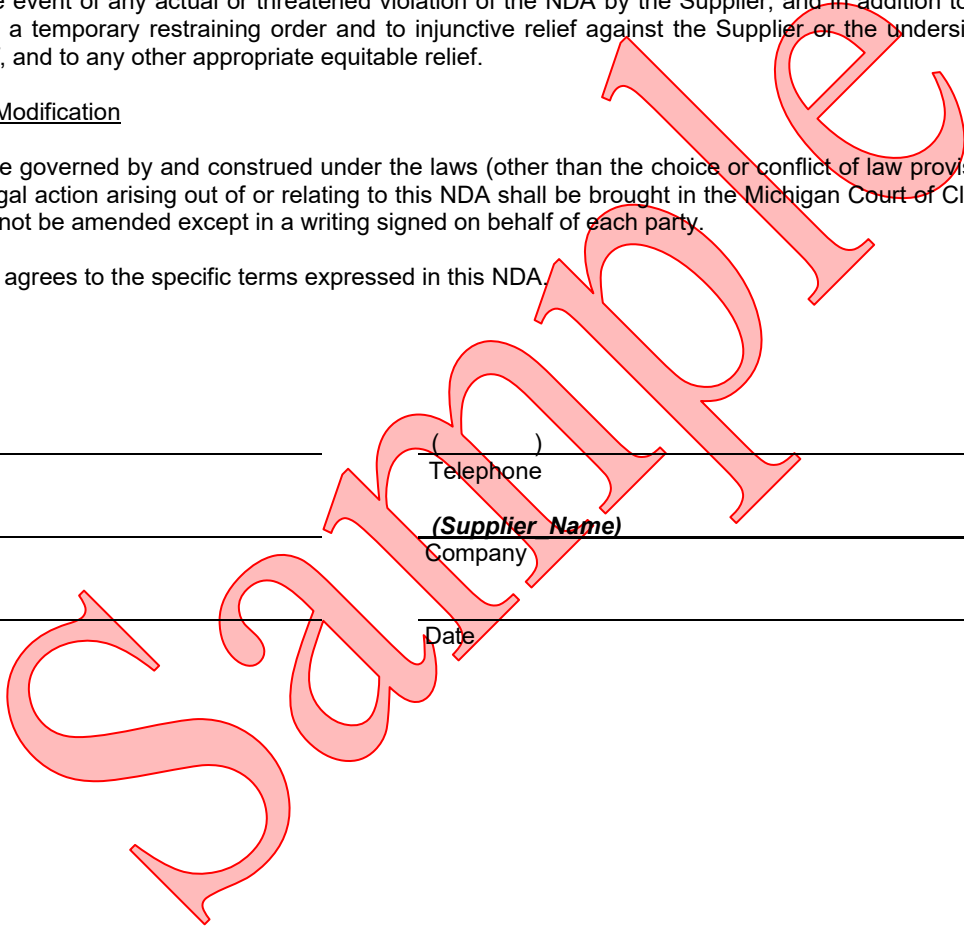



WAYNE STATE
UNIVERSITY

EXHIBIT C

Price or Rate Structure

Sample

Sample

WSU Cohn Nursing Classroom Renovation
Location: 5557 Cass Avenue, DETROIT, MI 48202
Project Number: ED2024-0063
Issued for Bid: 2024 07 02

FURNITURE BID DOCUMENTS

Owner Review

5557 Cass Avenue, DETROIT, MI 48
2024.07.02

WSU Cohn Nursing Classroom Renovation



PACKAGE

Cohn Nursing Classroom Renovation

SEATING TYPES:

MOBILE DISPLAYS STORAGE CARTS: MDSC

NESTING SCREEN MARKERBOARD: NSM

SMALL WHITEBOARDS: SMW

CHAIR: CH1

NON-FIXED RECTANGULAR TABLE: NFT

FIXED TABLES: FT1

LAPTOP STORAGE CART: LTSC

MOBILE DISPLAY STORAGE CARTS: MDSC

Product Info:

MANUFACTURER: KI Furniture or approved equal.

Style/Series: Rukus, Whiteboard Mobile Display Cart storage

Description: Mobile display cart is constructed with 1" diameter, 13-gauge steel tubing, bent, cut, welded and secured with fasteners. The side panels and inner shelf are constructed of 14-gauge steel, stamped and formed. All steel is powder-coat painted in various standard KI finishes. Storage section on the cart contains a non-skid pad. With two polypropylene 6" tote storage drawers.

Base Finish: Starlight Silver Metallic

Leg Finish: Starlight Silver Metallic

Frame Finish: Starlight Silver Metallic

Height: 53 3/4"

Width: 46 13/16"

Castors: Cottonwood/Warm Grey casters



Finish: Starlight Silver Metallic

Alternates

Steelcase

#	Rooms	QTY
MDSC	Classroom 101	3
MDSC	Classroom 102	1

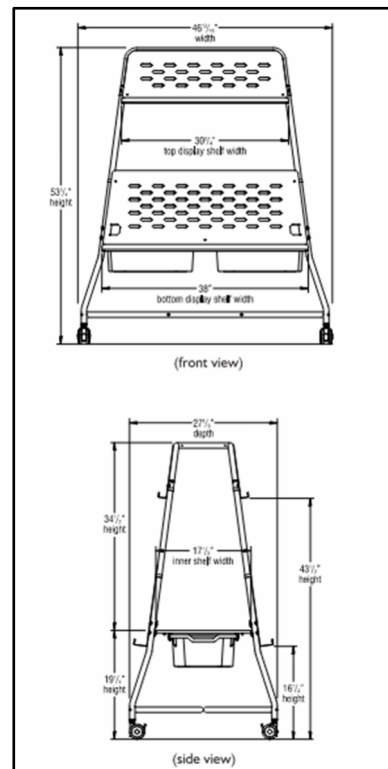

WSU Cohn Nursing Classroom Renovation
 Location: 5557 Cass Avenue, DETROIT, MI 48202
 Project Number: ED2024-0063
 Issued for Bid: 2024 07 02

NESTING SCREEN MARKERBOARDS: NSM

Product Info:

MANUFACTURER: KI Furniture or approved equal.
Style/Series: Tributaire, Nesting Screen, Markerboard
Description: Mobile Markerboard
Base Finish: Starlight Silver Metallic
Leg Finish: Starlight Silver Metallic
Frame Finish: Starlight Silver Metallic
Height: 54"
Width: 48"
Castors: Cottonwood/Warm Grey casters



Finish: Starlight Silver Metallic

Alternates

Steelcase

#	Rooms	QTY
NSM	Classroom 101	4

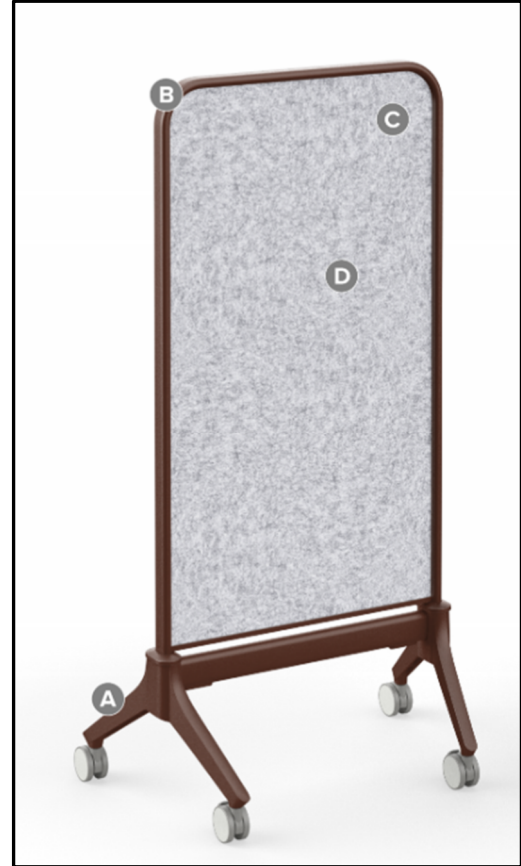

SMALL WHITEBOARDS: SMW

Product Info

MANUFACTURER: KI Furniture or approved equal.

Style/Series: Ruckus Small Whiteboard

Description: Dry-erase whiteboard surface is constructed of .08" thick opaque white polycarbonate resin with UV curing.

Frame Finish: Starlight Silver Metallic

Height: 12"

Width: 13"



Alternates

Steelcase

#	Rooms	QTY
SMW	Classroom 101	156
SMW	Classroom 102	32

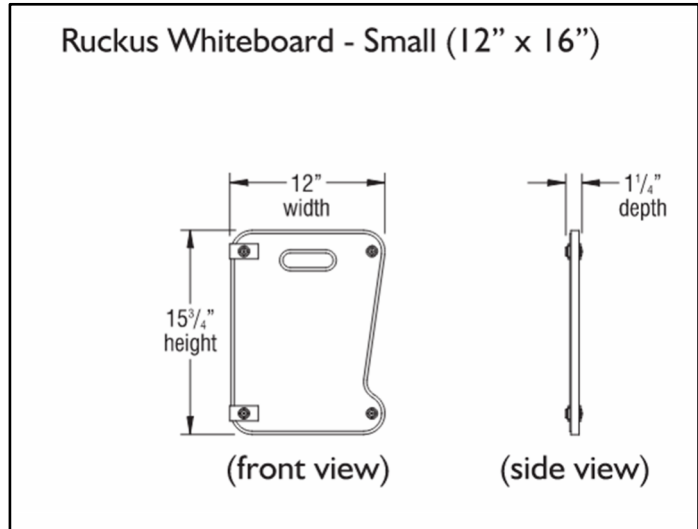

CHAIR: CH1

Product Info

MANUFACTURER: KI Furniture or approved equal.

Style/Series: LimeLite Task Armless

Description: LimeLite task chair offers a sophisticated look and flex back comfort with simple-function adaptability.

Shell Finish: Zesty Lime

Shell Compliance: TB 117-2013

Seat Fabric Finish: Avenue Dove

Armrest/Lever Color: Zesty Lime

Base/Caster/Cylinder Finish: Black



Finish: Zesty Lime



Finish: Warm Grey

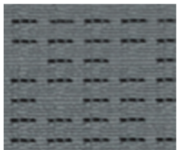

Finish: Avenue Dove



Alternates

Steelcase

#	Rooms	QTY
CH1	Classroom 101	157
CH1	Classroom 102	33

NON-FIXED TABLE: NFT

Product Info

MANUFACTURER: KI Furniture or approved equal.
Style/Series: Tributaire
Description: Non-Fixed Table Nesting Top Training, Rectangular Fixed table height with undermount coat hooks, fixed Modesty panel, Power/USB and capability to gang to fixed tables.
Pop-Up Power/USB Modules: Two (2) simplex receptacles ports, One USB-A Port, One USB-C Port, and One Blank Port Includes Infeeds, Jumpers, Troughs and Shrouds.
Pop-Up Power/USB Modules Finish: Warm Grey
Table Gang: Provide set of two for one Table to Table Gang
Table Top Finish: Laminate Grade 1, White
Tabletop width: 24"
Table Top Length: 60"
Table Height: 29"
Compliance: TB 117-2013
Modesty Panel Finish: Laminate Grade 1, White
Modesty Panel Height: 14"
Modesty Panel Length: 60"
Leg/Frame Finish: Warm Grey
Caster Finish: Warm Grey
Coat Hook Finish: Chrome, (1) one coat hook per seat

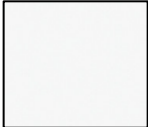
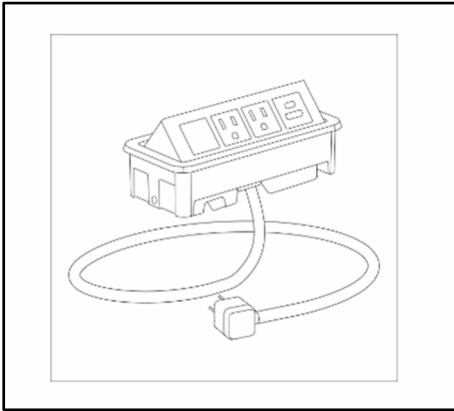

Finish: White



Finish: Warm Grey

Alternates

Steelcase

#	Rooms	QTY
NFT	Classroom 101	30
NFT	Classroom 102	16

FIXED TABLE: FT1

Product Info

MANUFACTURER: KI Furniture or approved equal.
Style/Series: Seminar Fix Tables
Description: Fixed Table Top Training, Rectangular
 Fixed table height with undermount coat hooks, fixed Modesty panel, Power/USB and capability to gang to non- fixed tables.
Pop-Up Power/USB Modules: Two (2) simplex receptacles ports, One USB-A Port, One USB-C Port, and One Blank Port Includes Infeeds, Jumpers, Troughs and Shrouds.
Pop-Up Power/USB Modules Finish: Warm Grey
Table Gang: Provide set of two for one Table to Table Gang
Table Top Finish: Laminate Grade 1, White
Tabletop width: 24"
Table Top Length: 60"
Table Height: 29"
Table Edge profile: Flat
Compliance: TB 117-2013
Modesty Panel Finish: Laminate Grade 1, White
Modesty Panel Height: 14"
Modesty Panel Length: 60"
Leg/Frame Finish: Basic style, Warm Grey
Caster Finish: Warm Grey
Coat Hook Finish: Chrome, (1) one coat hook per seat.

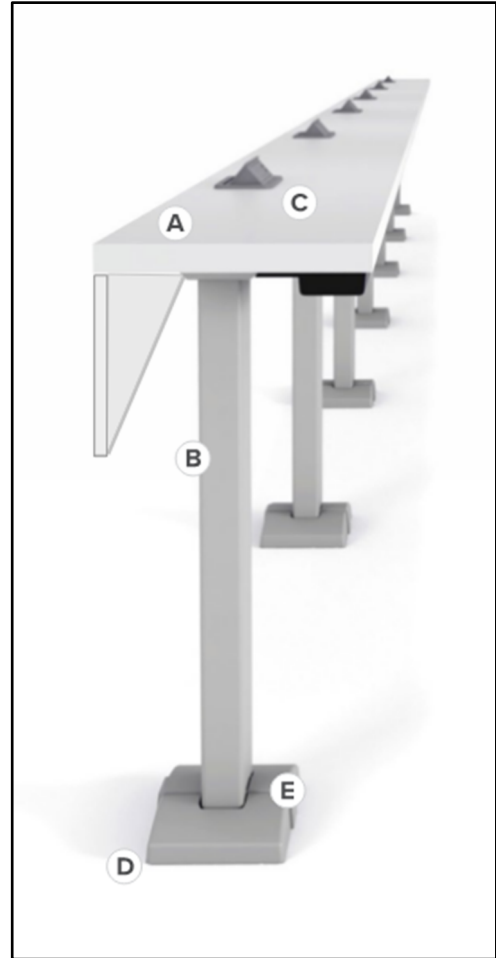

Finish: White



Finish: Warm Grey

Alternates

Steelcase

#	Rooms	QTY
FT1	Classroom 101	50

LAPTOP STORAGE CART: LTSC

Product Info

MANUFACTURER: LocknCharge or approved equal.
Style/Series: Carrier 20 Laptops & Tablet Charging Cart (4 Basket)
Description: Storage, Charge & Deploy Laptops & tablets, Supports Devices up to 13", Top-loading Design for Easy Retrieval, includes 4 x 5-Device Baskets, Bottom Section Holds Device Adapters, Neatly Route Cables via Side Channels, ECO Safe Charge Prevents Overcharging, 4 x Integrated Caster Wheels, Combination Padlock Included, Sturdy Welded Steel Construction
Overall Dimensions: 36.7" x 27.8" x 19.2"
Device Slots: 20
Lockable Cabinets: Yes, Key
Electrical Outlets: Yes
AC Input Power: 110 VAC, 60Hz at 15A
Cable Length: 9.8 ft
Material of Construction: Steel
Weight: 107.1 lbs / 48.6 Kg
Casters: (4) Four



Alternates

Bretford, Anthro, Spectrum Industries

<u>#</u>	<u>Rooms</u>	<u>QTY</u>
NFT	Classroom 101	3
NFT	Classroom 102	1